



NFPA 20 Fire Pump Diesel Panel

1. Product Information

ETNA - Automatic control panels for diesel engine pumps conforming to standard NFPA 20, having electronic control unit equipped with electrical instruments, warnings and communications on LCD display and with RS-485 serial connection for remote warnings, fitted internally with 3A battery charger.

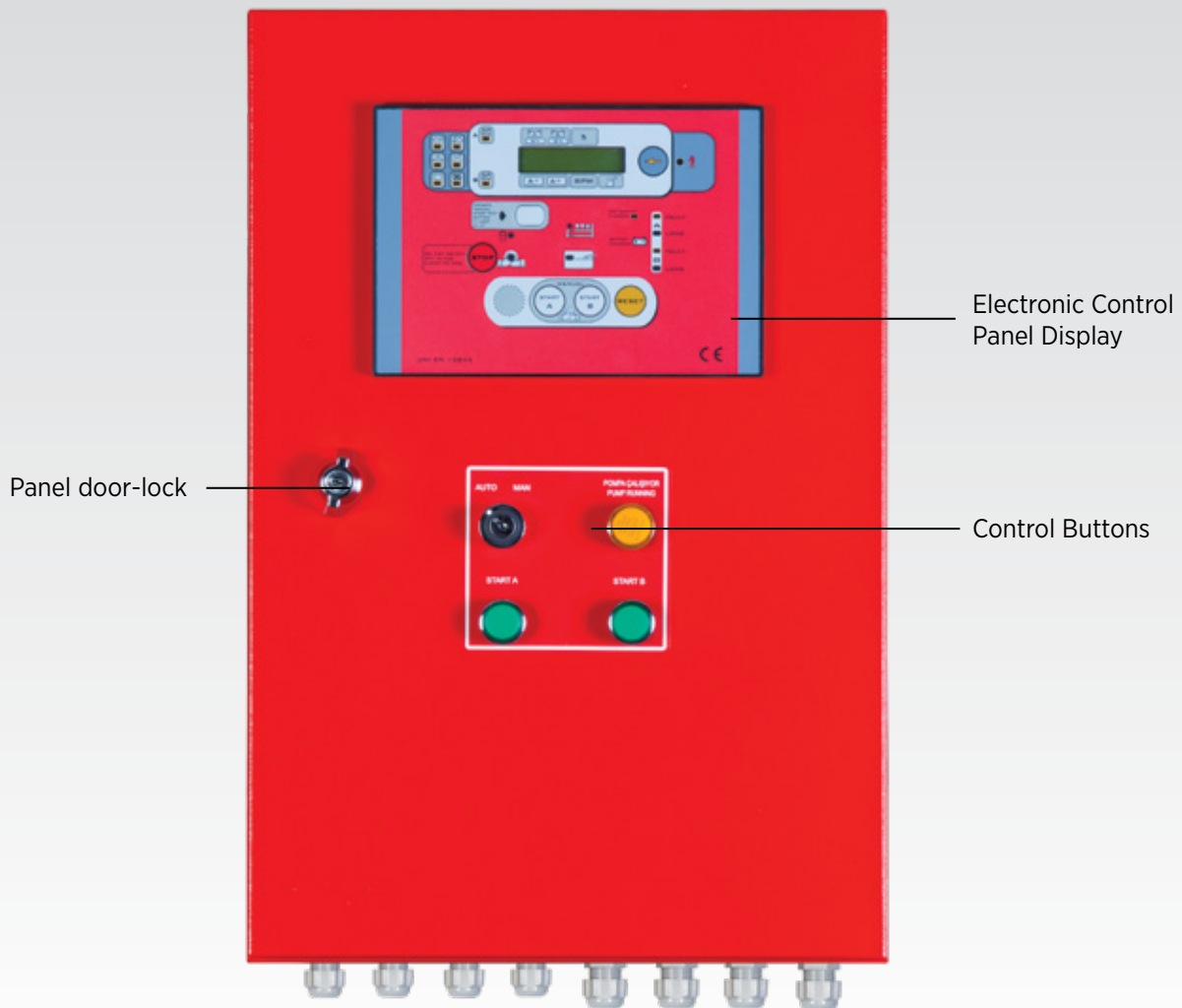

Figure 1. NFPA 20 Diesel Engine Control Panel - External View

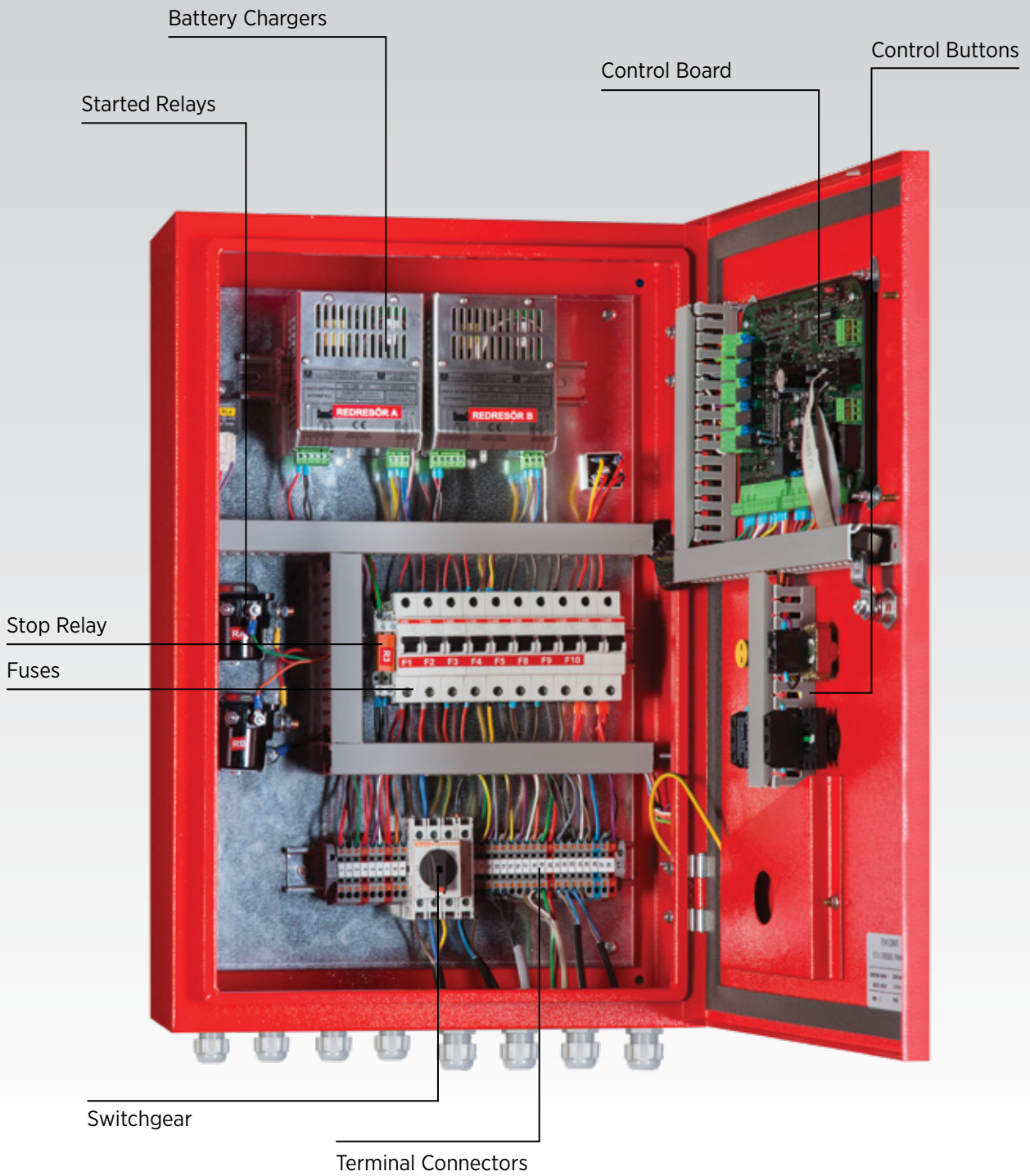
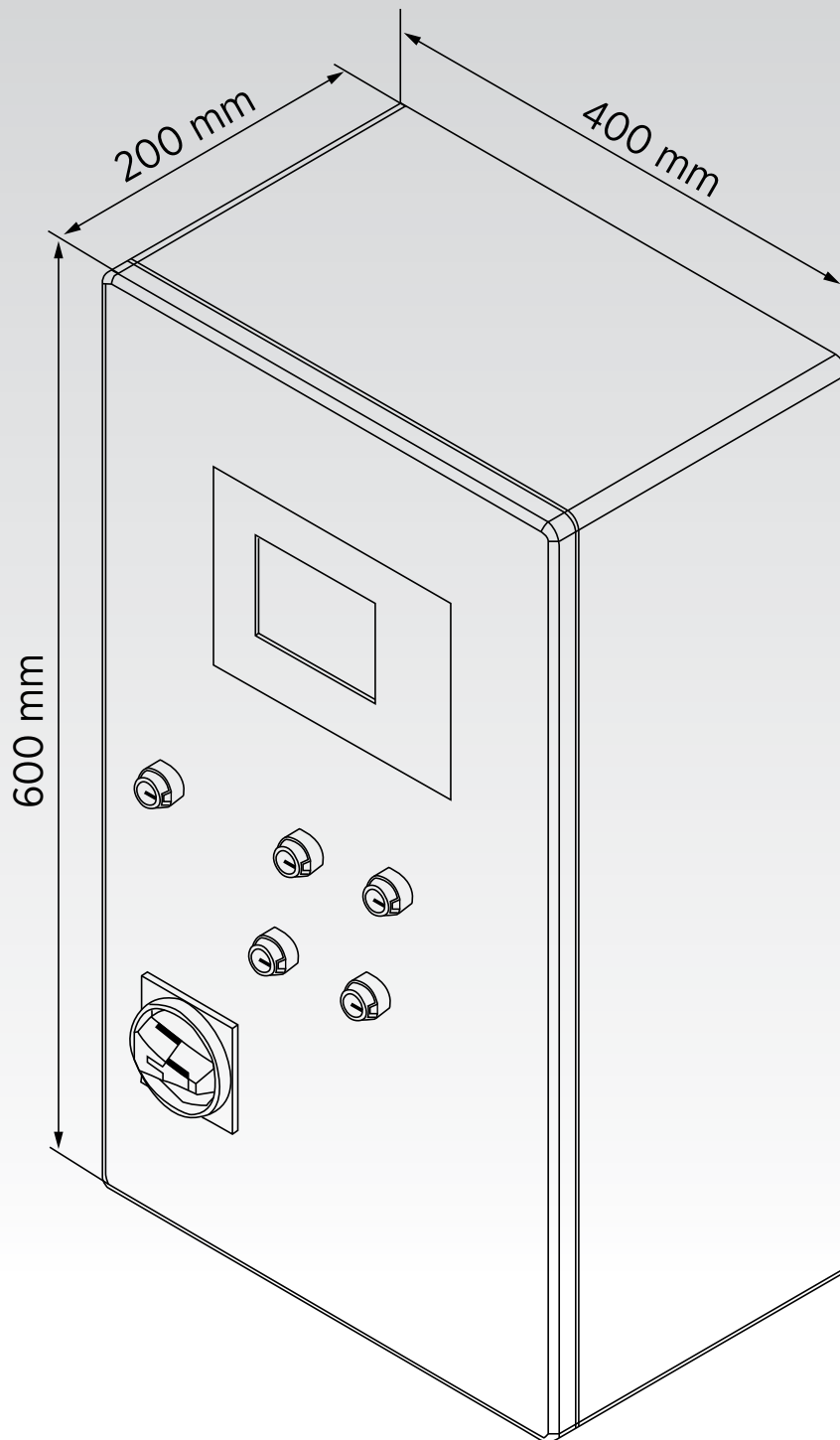

Figure 2. NFPA 20 Diesel Engine Control Panel - Internal View



2. Dimensions



3. Technical Specifications

- Epoxy coated DKP steel body
- 2 pcs battery , supply voltage 12 VDC and 24 VDC
- Supply Voltage 8/32 VDC Operating Frequency 50/60 Hz
- System load during Motor OFF 70 mA at 12 V , 40 mA at 24 V
- Maximum load 130 mA at 12 V ,70 mA at 24 V
- Time Display 4 digits
- Tachometer 4000 rpm \pm 15 rpm
- Battery charger voltmeter 38 V \pm %5
- Battery charger ammeter 99 A \pm %5
- Fuel level sensor precision %2
- Oil pressure sensor precision %2
- Water temperature sensor precision %2
- Manual Start / Stop Button
- MODBUS Serial communication (9600 Baud, 8 bit data, 1 bit stop, EVEN parity)
- Total Hour Meter (Total Hours Of Pump Operation)
- Partial Hour Meter (Operating hours and minutes of the last run)
- Schneider Switching Instruments

3.1 Functions that can be monitored remotely with no voltage contacts

- **Automatic start-up disabled** (automatic start-up switch disabled)  
- **Start up failure**
- **Pump operation**
- **Switchboard fault:** occurred engine alarms (excluded minimum fuel level), control unit power supply fault battery charger fault: mains failure, FLAT CABLE not connected and blown fuses (the battery charger fuses are signalled as: CHARGER BATTERY FAULT and INEFFICIENT BATTERY).
- **Minimum fuel level.**

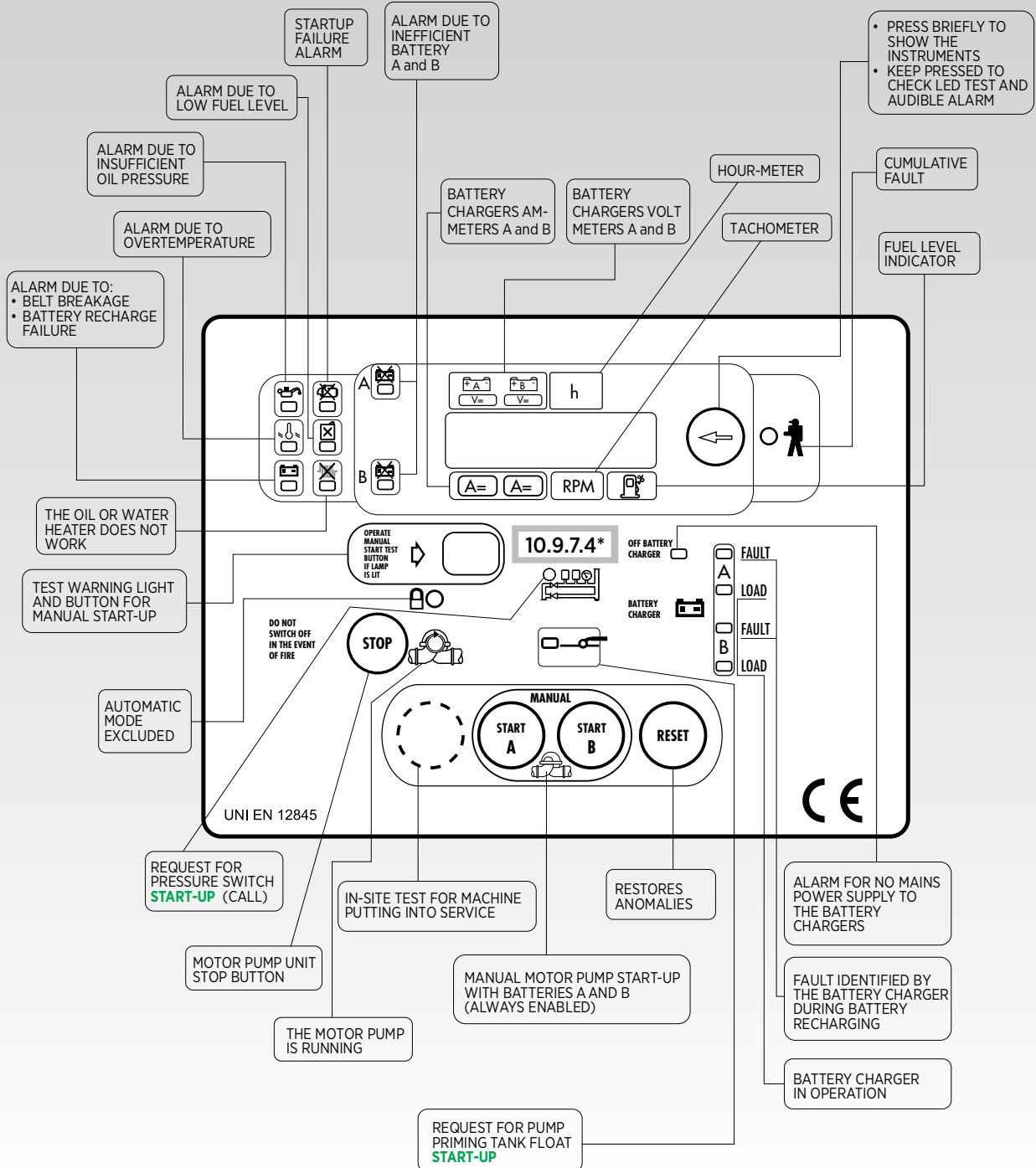

Figure 3. Control Panel Buttons and Indicators

Rev. 01/2021



Dudullu Organize Sanayi Bölgesi 2. Cadde No: 14
34775 Ümraniye İstanbul / Turkey
Tel : +90 216 561 47 74 (Pbx) • Fax : +90 216 561 47 50
www.etna.com.tr/en • info@etna.com.tr



ETNA®

0850 455 38 62
customer service